

THIS DRAWING IS UNPUBLISHED. RELEASED FOR PUBLICATION
 © COPYRIGHT BY TYCO ELECTRONICS CORPORATION. ALL RIGHTS RESERVED.

LOC	DIST	REVISIONS					
		P	LTR	DESCRIPTION	DATE	DWN	APVD
G	14		G1	REDRAWN PER ECR 07-001176	16JAN07	JR	TM

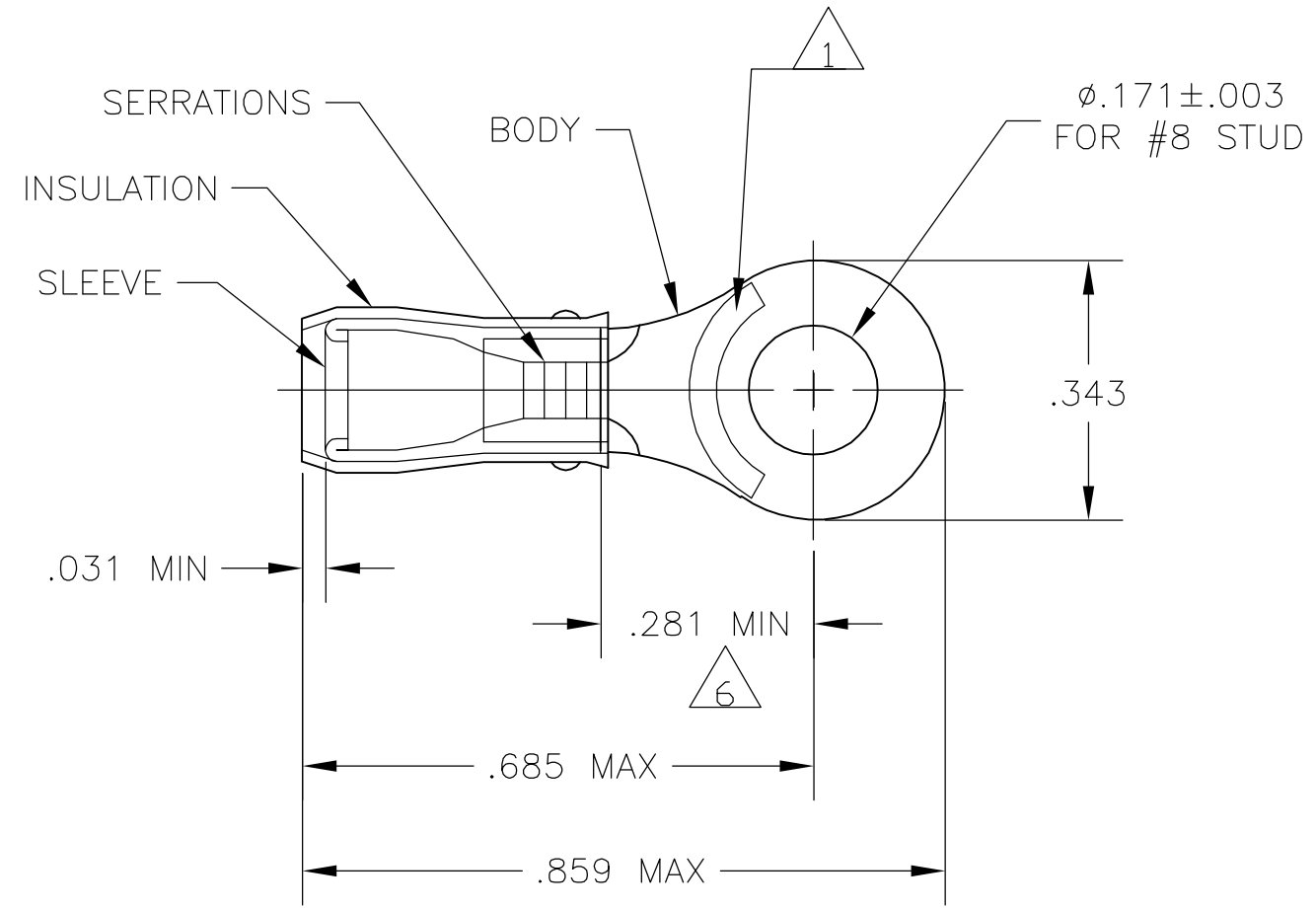

- 1 STAMP AMP 16-14* APPROX AS SHOWN
- 2 WIRE INSULATION DIA: .115-.170
- 3 TONGUE MATERIAL THK: .031±.002
- 4 BODY & SLEEVE: TIN PLATE PER ASTM B545,
- 5 BODY & SLEEVE- CU PER ASTM B152 INSULATION - NYLON, COLOR - BLUE
- 6 APPLIES FROM EDGE OF METAL WIRE BARREL TO CENTER OF STUD HOLE.

100	LOOSE PIECE, BOX	8-320565-1
5000	320565 ON TAPE	2-320565-1
1000	LOOSE PIECE	320565
QTY	PACKAGE TYPE	PART NO

AMP INCORPORATED CUSTOMER SERVICE SYSTEMS		MAX RECOMMENDED OPERATING TEMPERATURE: 105°C MAX	THIS DRAWING IS A CONTROLLED DOCUMENT.		DWN JR RUTH 16JAN07	Tyco Electronics Corporation Harrisburg, Pa 17105-3608				
FOR ADDITIONAL PRODUCT INFORMATION OR COPIES OF DRAWINGS AND TECHNICAL DOCUMENTS	PRODUCT INFORMATION CENTER 1-800-522-6752	VOLTAGE RATING: -	DIMENSIONS: INCHES	TOLERANCES UNLESS OTHERWISE SPECIFIED:	CHK T MICHIELUTTI 16JAN07			NAME T MICHIELUTTI		
FOR APPLICATION TOOLING INFORMATION	TOOLING ASSISTANCE CENTER 1-800-722-1111	CIRCULAR MIL AREA: 1.04-2.62mm ² [2,050-5,180] STRANDED		0 PLC ± - 1 PLC ± - 2 PLC ± - 3 PLC ± - 4 PLC ± - ANGLES ± -	APVD T MICHIELUTTI 16JAN07	PRODUCT SPEC -				
FOR ORDER ENTRY	1-800-526-5142	THIS DRAWING IS A CONTROLLED DOCUMENT FOR AMP INCORPORATED. IT IS SUBJECT TO CHANGE AND THE CONTROLLING ENGINEERING ORGANIZATION SHOULD BE CONTACTED FOR THE LATEST REVISION.	MATERIAL -	FINISH -	APPLICATION SPEC -	WEIGHT -	SIZE A3	CAGE CODE 00779	DRAWING NO G-320565	RESTRICTED TO -
			CUSTOMER DRAWING		SCALE 4:1	SHEET 1	OF 1	REV G1		